

# MV-DP2470-01P

## 3D Laser Profile Sensor



### Introduction

With built-in high-accuracy algorithm, image process algorithm of wide dynamic range, and data integration algorithm, MV-DP2470-01P can output high accurate 3D point cloud data in real-time by combining high frame rate chip and accurate laser control. With compact structure, high integration, and easy operation, it is widely applied into 3C industry, electronics manufacturing, automobile, etc.

### Available Model

MV-DP2470-01P

### Applicable Industry

3C industry, electronics manufacturing, automobile, etc.

### Dimension

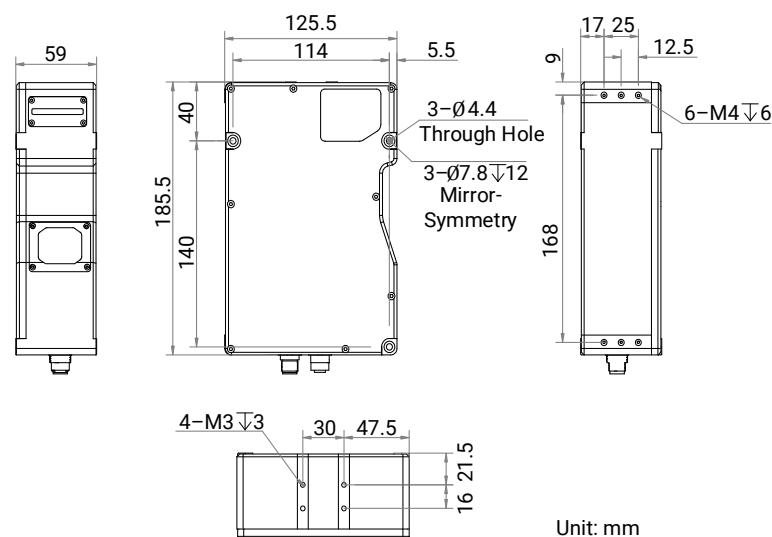

### Key Feature

- Built-in high-accuracy algorithm and accuracy is up to submicron level.
- Adopts high frame rate chip with 10 KHz scan frame rate.
- Supports multiple exposure modes with good robustness.
- Adopts multiple-frame integration technology to provide complete profiles.
- Provides multiple filter modes with stable data.
- Supports ROI selection and auto setting for easier operation.

### Measurement Range Diagram

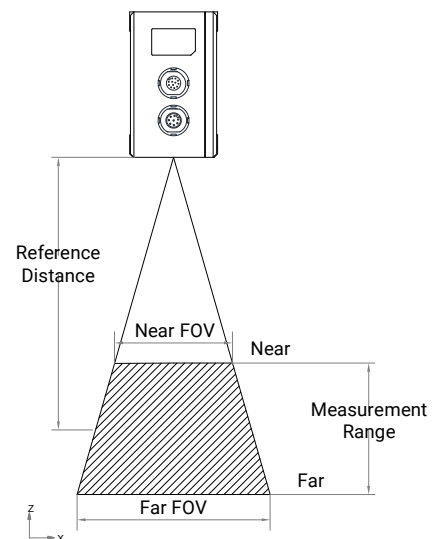

## Specification

Model	MV-DP2470-01P
Parameter	3D Laser Profile Sensor
<b>Performance</b>	
Data points/profile	2048
Reference distance	565 mm
Measurement range (Z-axis)	670 mm
Measurement range (X-axis)	142 mm @ near field of view 315 mm @ reference distance 488 mm @ far field of view
Resolution (Z-axis)	10.39 $\mu\text{m}$ to 169.79 $\mu\text{m}$
Repeatability (Z-axis)*	4.45 $\mu\text{m}$ @ data that sensor tests gauge block on optical platform
Linearity Z-axis ( $\pm\%$ of MR)	0.01
Profile data interval	68.6 $\mu\text{m}$ to 277.0 $\mu\text{m}$
Scan frame rate	660 Hz (within max. measurement range), max. 10 kHz (in ROI mode)
Data output	Profile data, depth image, brightness image
Trigger mode	Software trigger, external trigger (differential encoder)
Laser safety class	Class 3B
Wavelength	405 nm
<b>Electrical feature</b>	
Data interface	Gigabit Ethernet (1000 Mbit/s), compatible with Fast Ethernet (100 Mbit/s)
Digital I/O	12-pin M12 interface provides power and I/O, including differential input $\times$ 3 (Line 0/3/6), differential output $\times$ 1 (Line 1), and RS-232 $\times$ 1
Power supply	24 VDC
Power consumption	13.8 W @ 24 VDC
<b>Mechanical</b>	
Dimension	185.5 mm $\times$ 125.5 mm $\times$ 59 mm (7.3" $\times$ 4.9" $\times$ 2.3")
Weight	Approx. 1450 g (3.2 lb.)
Ingress protection	IP67
Temperature	Working temperature: 0 $^{\circ}\text{C}$ to 45 $^{\circ}\text{C}$ (32 $^{\circ}\text{F}$ to 113 $^{\circ}\text{F}$ ) Storage temperature: -30 $^{\circ}\text{C}$ to 80 $^{\circ}\text{C}$ (-22 $^{\circ}\text{F}$ to 176 $^{\circ}\text{F}$ )
Humidity	20% RH to 85% RH (no condensation)
<b>General</b>	
Client software	3DMVS, VM3D, or third-party software
Operating system	32/64-bit Windows 7/10, 64-bit Windows 11 (8 GB memory and above, and i5 CPU recommended)

\*This data is obtained via testing gauge blocks in a laboratory, and it is an average from 4096 tests.